

**INSTRUCTIONS FOR OPERATION,
SERVICE AND MAINTENANCE FOR PS12
POWERLINE SLICER**

INSTRUCTIONS FOR OPERATION, SERVICE AND MAINTENANCE FOR PS12 POWERLINE SLICER

CONTENT

	PAG.
UNPACKING	3
INSTALLATION	4
OPERATION	5
KEY ELEMENTS IN SLICING QUALITY PRODUCT	6
CLEANING	7
MAINTENANCE	8
PARTS LIST	9

INTRODUCTION:

CONGRATULATIONS YOU HAVE ACQUIRED A POWERINE SLICER WHICH IS MADE OF HIGH QUALITY LONG LASTING MATERIALS THAT SHOULD GIVE YOU YEARS OF TROUBLE FREE OPERATION AND DURABLE SERVICE.

BEFORE YOU UNPACK YOUR NEW POWERLINE SLICER, IT IS OF VITAL IMPORTANCE THAT YOU AND ANY PERSON THAT WILL OPERATE THIS UNIT THOROUGHLY READ THIS MANUAL.

WARNINGS:

- THIS MACHINE IS DESIGNED TO CUT FOOD PRODUCTS AND IS BY NATURE DANGEROUS IF NOT USED AND MAINTAINED PROPERLY AND CAUTIOUSLY FOR OPTIMUM SAFETY.
- DO NOT ALLOW UNTRAINED OR UNQUALIFIED PERSONNEL TO OPERATE THIS EQUIPMENT.



- NEVER PERFORM SERVICE, CLEANING OR MAINTENANCE ON THIS UNIT WHILE IT IS CONNECTED TO A POWER SOURCE.



- NEVER USE HANDS OR FINGERS TO FEED PRODUCTS TO CUT; DO NOT PLACE FINGERS OR HANDS WITHIN 4" (FOUR INCHES), OF THE BLADE, WHILE IN OPERATION.

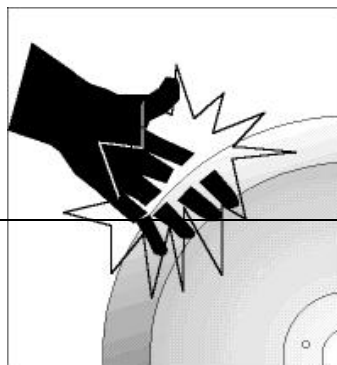

- **THE MOST DANGEROUS COMPONENT OF THIS EQUIPMENT IS THE BLADE; ALWAYS EXERCISE EXTREME CAUTION WHILE CLEANING OR SERVICING AND USE CUT RESISTANT STEEL OR PLASTIC GLOVES FOR CLEANING OR SERVICE.**



- **DO NOT LEAVE THE MACHINE UNATTENDED WHILE IN OPERATION.**

I.- UNPACKING:

- 1.- WHILE UNPACKING THE MACHINE TAKE SPECIAL CARE IN REMOVING THESE COMPONENTS AND MAKE SURE THAT ALL ARE ACCOUNTED FOR.
 - 1 BASE (10) UNIT INCLUDING KNIFE (2), MOTOR AND SHARPENER (13).*
 - 1 CARRIAGE ASSY. (4) WITH GRIP (15).

* **NOTE:** FOR REFERENCE NUMBERS REFER TO FIG. 6

- A.- TAKE OUT THE CARRIAGE (4), AND REMOVE THE FOAM PROTECTORS.
- B.- REMOVE THE CARDBOARD PROTECTORS (FIG. 1).
- C.- DEFINE THE PLACE TO SET THE MACHINE.
- D.- TAKE OUT THE MACHINE, LIFTING FROM THE BASE, (EXERCISE PROPER LIFTING METHOD PREFERABLY DO THIS PROCEDURE WITH TWO PERSONS).
- E.- ONCE THE UNIT IS FIRMLY ON THE INTENDED PLACE OF OPERATION, REMOVE THE FOAM PROTECTOR FROM THE KNIFE SHARPENER (13).
- F.- REMOVE THE KNIFE EDGE PROTECTOR; TO DO THIS:
 - ROTATE THE THICKNESS CONTROL KNOB (6) UNTIL IT STOPS COUNTER CLOCKWISE.
 - REMOVE THE KNIFE GUARD (12) BY ROTATING COUNTER CLOCKWISE THE RETAINER SHAFT KNOB (22) ALL ITS TRAVEL AND THEN LIFT THE BLADE GUARD (12).
 - EXERCISE EXTREME CAUTION TO REMOVE THE KNIFE EDGE PROTECTOR BY FINDING THE PROTECTOR JOINT AND REMOVING THE PROTECTOR BY LIFTING IT FROM THE KNIFE. (ALWAYS WEAR HAND AND FINGER PROTECTION FOR THIS OPERATION).
 - ONCE THE KNIFE EDGE PROTECTOR IS REMOVED, REPLACE THE KNIFE GUARD (12) AND TIGHTEN SECURELY. CLOSE THE THICKNESS GAGE (5) BY ROTATING THE SLICE ADJUSTING KNOB (6) CLOCKWISE FULLY.

WARNING:

TAKE SPECIAL CARE WHEN YOU TAKE APART THE KNIFE PROTECTOR, THE KNIFE IS ALREADY SHARP FROM THE FACTORY AND WITHOUT PROTECTOR SERIOUS INJURY MAY HAPPEN.

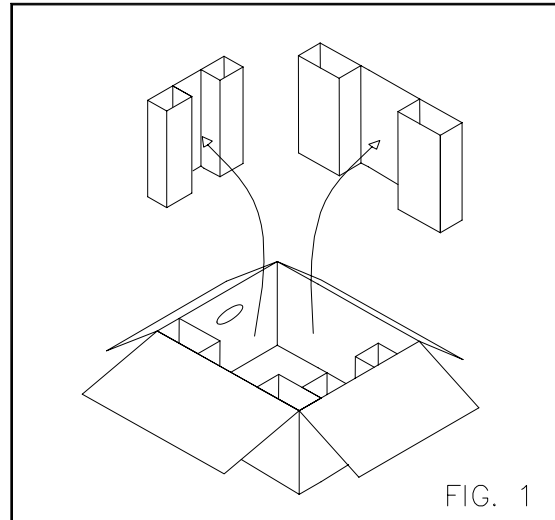

II.- INSTALLATION:

BEFORE CONNECTING TO THE POWER SOURCE FOLLOW THIS EASY ASSEMBLY AND PREPARATION STEPS. (NEVER EXECUTE THESE PROCEDURES WITH THE CORD PLUGGED TO THE POWER SOURCE).

1.- ASSEMBLE THE CARRIAGE (FIG. 2) ON THE SLICER, FOLLOWING THESE STEPS:

A.- PLACE CARRIAGE (4) ON CARRIAGE SUPPORT (3).

B.- TIGHTEN CARRIAGE KNOB (1) FIRMLY, DON'T FORGET THE PLASTIC RING BETWEEN THE CARRIAGE AND KNOB.

2.- SET THE SLICER ON A CLEAN AND LEVEL PLACE.

3.- ROTATE THE THICKNESS CONTROL KNOB (6) TO BE SURE THAT IT WORKS FREELY ALL THE WAY THROUGH, AND CHECK THAT THE THICKNESS TABLE OPENS AND CLOSES SIMULTANEOUSLY.

NOTE: CHECK THE POWER REQUIREMENTS OF THE UNIT, NORMALLY 110 VOLTS, 60 HZ. AND GROUNDED, (THE VOLTAGE OF THE MOTOR CAN BE CHANGED TO 220 VOLTS, BY A QUALIFIED ELECTRICIAN, TO DO THIS PLEASE CONTACT YOUR POWERLINE DEALER).

4.- CONNECT THE SLICER TO THE POWER SOURCE. THE POWER SOURCE SHOULD BE CLOSE ENOUGH TO THE MACHINE TO PROVIDE EASE OF DISCONNECTION FOR CLEANING AND SERVICE.

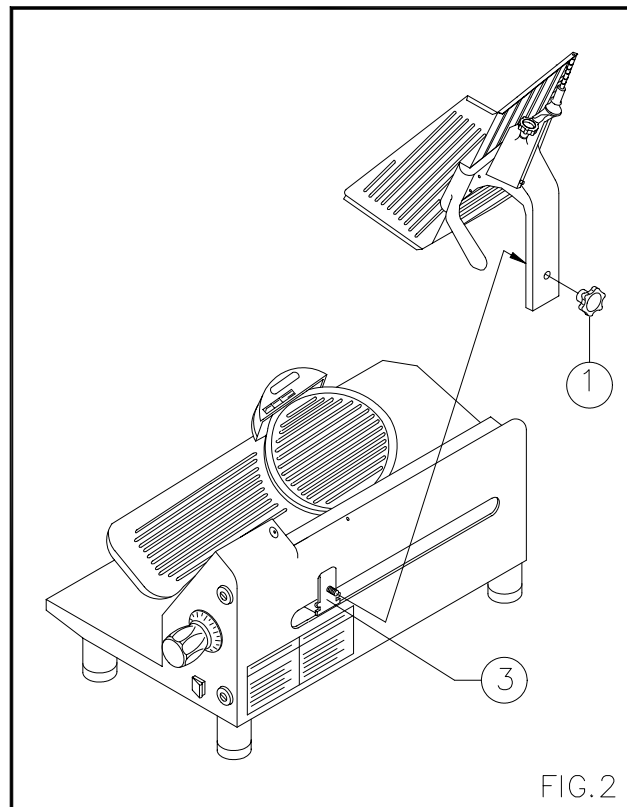

WARNING:

**NEVER OPERATE THE MACHINE WITHOUT PROPER TRAINING
SERIOUS INJURY MAY HAPPEN.**

III.- OPERATION:

IMPORTANT: FOR THE FIRST TIME USAGE, YOU MUST CLEAN THE MACHINE AND ALSO CUT A COUPLE OF SLICES OF SCRAP PRODUCT (YOU CAN USE CARROTS, POTATOES ETC.) TO BE SURE THAT THE KNIFE IS CLEAN BEFORE CUTTING EDIBLE PRODUCT.

NORMAL OPERATION OF THE SLICER:

- 1.- PLACE THE PRODUCT TO BE CUT ON THE CARRIAGE TRAY (4).
- 2.- UNLOCK THE GRIP (15) FROM UNDER THE CARRIAGE TRAY, USING THE GRIP-KNOB (14), TO DO THIS YOU MUST MOVE THE GRIP (15) TO THE TOP OF THE SLIDE ROD DO NOT FORCE THIS OPERATION, THEN ROTATE THE GRIP COUNTER CLOCKWISE TO ITS POSITION OVER THE CARRIAGE TRAY.
- 3.- PUSH THE GRIP BY THE KNOB ALL THE WAY DOWN ON THE PRODUCT, THEN USING THE GRIP-KNOB (14) YOU CAN SLIDE THE CARRIAGE BACK AND FORTH WITH THE SAME HAND OR USE THE CARRIAGE HANDLE (8).
- 4.- MOVE THE CARRIAGE ALL THE WAY BACK AND SELECT THE THICKNESS USING THE ADJUSTING KNOB (6).
- 5.- TURN ON THE MACHINE USING THE ROCKER SWITCH (7), THE PILOT SAFETY LIGHT SWITCH GIVES WARNING THAT THE SLICER IS RUNNING.

- 6.- NOW YOU CAN START TO SLICE THE PRODUCT; THIS MACHINE HAS BEEN DESIGNED WITH A 45° ANGLE SO THAT MINIMUM EFFORT IS REQUIRED TO PUSH THE PRODUCT THROUGH THE CUT. FOR BEST RESULTS, KEEP KNIFE SHARP.
- 7.- WHEN FINISHED, ALWAYS TURN THE MACHINE OFF BY USING THE SWITCH (7) AND TURN THE SLICE ADJUSTING KNOB CLOCKWISE AS FAR AS IT WILL GO (BE SURE THAT THE PLATE (5) COVERS THE EDGE OF THE KNIFE TO PREVENT ANY POSSIBLE ACCIDENT).
- 8.- REPLACE THE GRIP (15) TO IT'S STOWED POSITION UNDER THE CARRIAGE, FOLLOWING THE STEPS IN POINT 2.

NOTE: TO SLICE ANOTHER PRODUCT JUST FOLLOW ALL THE PREVIOUS STEPS

WARNING:

**NEVER LEAVE THE MACHINE UNATTENDED WHILE IN OPERATION
SERIOUS INJURY MAY HAPPEN.**

IV.- KEY ELEMENTS IN SLICING QUALITY PRODUCT:

- 1.- DO NOT FORCE THE CUT AGAINST THE KNIFE (2).
- 2.- KEEP KNIFE EDGE SHARP TO INSURE EASE OF CUTTING AND ENHANCE PRODUCT APPEARANCE.

NOTE: THE RE-SHARPENING PROCEDURE STEPS ARE SHOWN IN SECTION VI
MAINTENANCE.

- 3.- KEEP THE PLATE (5), THE CARRIAGE TRAY, THE KNIFE (2), AND THE RECEIVING TRAY FREE OF SCRAPS AND DEBRIS.

NOTE: NEVER ATTEMPT ANY CLEANING WHILE THE MACHINE IS CONNECTED TO
THE POWER SOURCE.

V.- CLEANING:

WARNING

ALWAYS UNPLUG OR DISCONNECT THE MACHINE FROM THE POWER SOURCE BEFORE ATTEMPTING CLEANING OR SERVICE

NOTE: IT IS RECOMMENDED TO CLEAN THE MACHINE DAILY, WITH A SOFT DAMP CLOTH, AND A SOFT BRUSH WITH APPROVED MILD DETERGENT AND WATER **DO NOT CLEAN THE MACHINE WITH A WATER HOSE. DO NOT SUBMERGE THE UNIT INTO WATER OR OTHER LIQUIDS.**

FOR DAILY CLEANING YOU MUST CLEAN ALL THE COMPONENTS MENTIONED ON POINT 3 SECTION IV. FOR A MORE THOROUGH CLEANING FOLLOW THESE EASY STEPS.

- 1.- LEVEL THE THICKNESS GAGE PLATE (5) WITH THE KNIFE GUARD PLATE (12) USING THE SLICE ADJUSTING KNOB (6).
- 2.- PLACE THE GRIP (15) IN IT'S STOWED POSITION UNDER THE CARRIAGE TRAY.
- 3.- REMOVE THE CARRIAGE FROM ITS SUPPORT USING THE CARRIAGE-KNOB (1).
- 4.- REMOVE THE SCRAP TRAY (23) THAT IS LOCATED UNDER THE KNIFE, JUST PULL-UP SLIGHTLY AND REMOVE IT.
- 5.- REMOVE THE SHARPENER ASSY.(FIG. 3), BY LOOSENING THE SHARPENER-KNOB (21) AT THE BOTTOM OF THE ASSY, AND THE PULL THE ASSY UP.

NOTE: YOU CAN SPLIT THE SHARPENER COVER LOOSENING THE SMALL KNOB (18) IN ORDER TO CLEAN THE WHOLE SHARPENER ASSY. (FIG. 4).

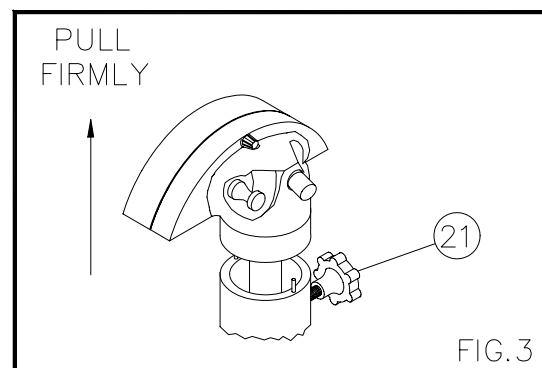

- 6.- ALSO YOU MAY REMOVE THE KNIFE COVER PLATE (12), FOR DEEPER CLEANER. **BUT, BE EXTREMELY CAREFUL, WHEN THE KNIFE EDGE IS PARTIALLY EXPOSED OR TOTALLY EXPOSED IT IS EXTREMELY DANGEROUS.**
- 7.- AFTER THESE STEPS YOU CAN GIVE A DEEPER CLEANING TO ALL COMPONENTS, AFTER CLEANING REASSEMBLE IN REVERSE ORDER.

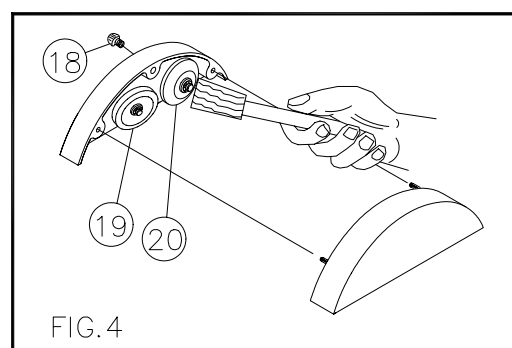

VI.- MAINTENANCE:**WARNING**

ALWAYS DISCONNECT THE MACHINE FROM THE POWER SOURCE BEFORE EXECUTING ANY SERVICE OR MAINTENANCE.

- 1.- **SLIDE RODS:** YOU MUST LUBRICATE THE SLICER AT LEAST EVERY 100 HOURS OF SERVICE OR 30 DAYS WITH LIGHT OIL. THE POINTS TO LUBRICATE ARE (16) AND (17) SHOWN IN FIG. 6.
- 2.- **KNIFE:** AFTER MANY HOURS YOU WILL NEED TO RE-SHARPEN THE KNIFE, THE STEPS AS ARE FOLLOWS:
 - A.- BE SURE THE MACHINE IS OFF.
 - B.- LOOSEN THE KNOB (21) UNDER THE SHARPENING ASSY., UNTIL THE ASSY. SPRINGS UP (FIG. 5).

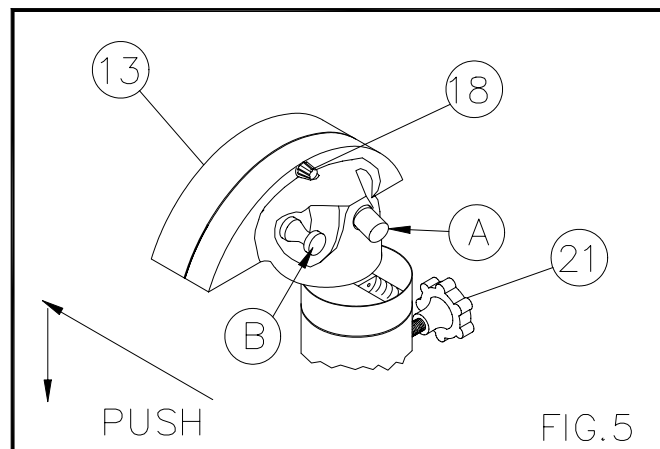

- C.- PUSH THE ASSY. ALL THE WAY FORWARD TOWARDS THE KNIFE EDGE, HOLD IT IN THAT POSITION AND PRESS DOWN UNTIL THE STONES ARE ON EACH SIDE OF THE KNIFE (APROX. 1/4" UNDER THE EDGE), THEN TIGHTEN THE KNOB AGAIN.
- D.- TURN ON THE MACHINE, AND PUSH THE ROD " A " ON FIG 5, LET THE STONE GRIND THE UNDER SIDE OF THE KNIFE FOR A FEW SECONDS. THIS WILL SHARPEN THE EDGE AND CREATE A SLIGHT BURR ON THE TOP SIDE OF THE EDGE. WHEN YOU RELEASE THE ROD "A" IT WILL RETURN AUTOMATICALLY.
- E.- THEN REMOVE THE BURR FROM THE TOP SIDE OF THE KNIFE BY PULLING DOWN ROD "B". ONLY A VERY SLIGHT PRESSURE IS NEEDED TO HOME THE EDGE. TOO MUCH PRESSURE AND TIME CAN CREATE A REVERSE ANGLE AND DESTROY KNIFE EDGE. ROD "B" WILL RETURN AUTOMATICALLY WHEN RELEASED.

IMPORTANT: THE TIME SPENT IN GRINDING AND TRUING THE KNIFE EDGE WILL ADD TO LONGEVITY OF THE KNIFE AND PROVIDE OPTIMUM EFFICIENCY OF YOUR POWERLINE SLICER. REPEAT STEPS D AND E IF NECESSARY.

ITEM	DESCRIPTION	QTY
1	CARRIAGE SUPPORT KNOB	1
2	KNIFE	1
3	CARRIAGE SUPPORT	1
4	CARRIAGE SUB-ASSEMBLY	1
5	THICKNESS GAGE PLATE	1
6	SLICE ADJUSTING KNOB	1
7	SWITCH WITH PILOT LIGHT	1
8	CARRIAGE BASE	1
9	SUPPORT FOOT RUBBER	4
10	SLICER BASE FRAME	1
11	MOTOR 1/3HP (NOT SHOWN)	1
12	KNIFE GUARD PLATE	1
13	SHARPENER AND COVER SUB-ASSEMBLY	1
14	GRIP KNOB	1
15	GRIP	1
16	LUBRICATION TUBE	1
17	OIL PORT	1
18	SHARPENER COVER KNOB	1
19	GRINDING STONE	1
20	TRUING STONE	1
21	SHARPENER LOCK KNOB	1
22	KNIFE GUARD KNOB	1

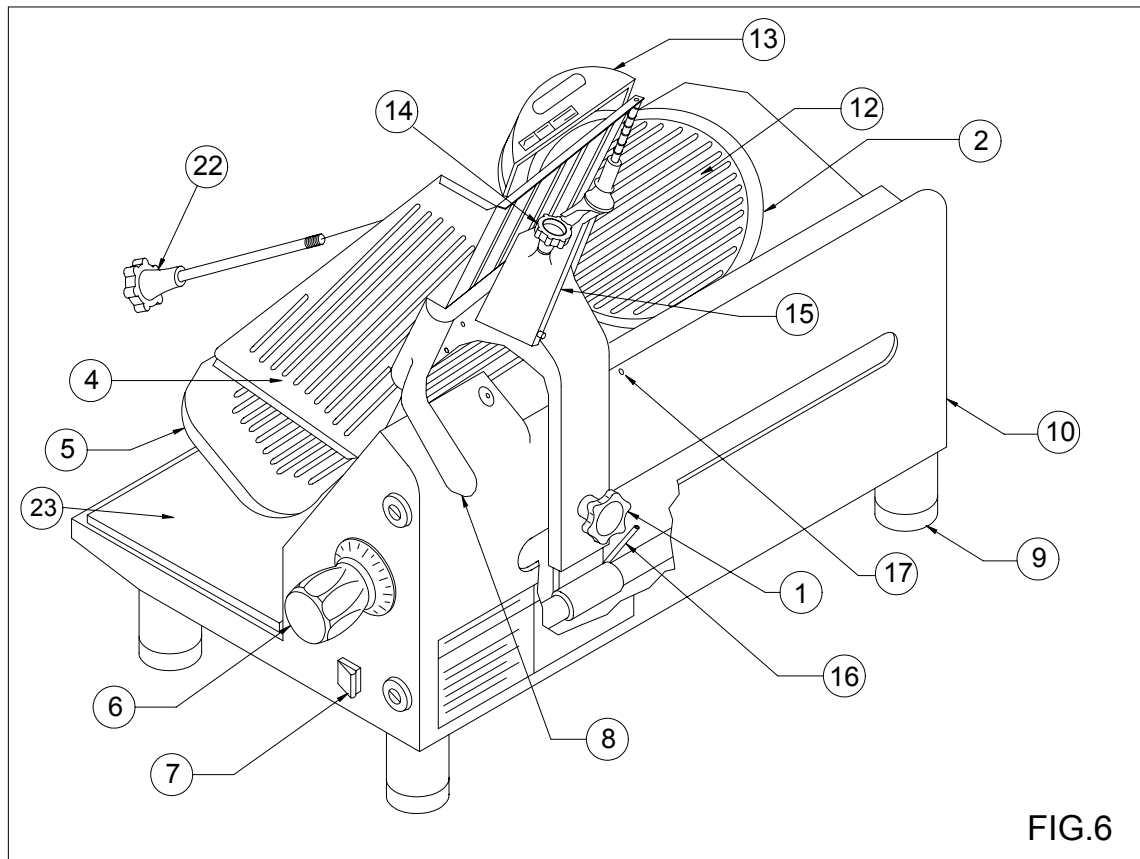

FIG.6

THANK YOU FOR SPENDING THE TIME TO READ THIS MANUAL.
IF THERE ARE ANY QUESTIONS PLEASE CONTACT POWERLINE EQUIPMENT
WEB SITE: www.powerlineequip.com
Tel. No. (1-203) 847-2357
Fax. No. (1-203) 847-6480