



EQUIPMENT

POWERLINE BOWL CUTTER BC-14

STANDARD FEATURES

Powerline Bowl Cutters are designed for large volume production of numerous food preparation tasks. Twin stainless steel knives make 3,500 cuts per minute of products that vary from parsley and root vegetables to meats, cheeses and breads. The stainless steel bowl revolves at 24 RPM. The more product that passes through the knives, the finer the cut the BC-14 will make. This model is also excellent for spreads, dips and salads. Additional accessories include the (1000450) heavy duty clear plastic cover.



POWERLINE BOWL CUTTER BC-14

Technical Data

Motor	1/2 HP Capacitor start at a speed of 1725 RPM 6 Amps
Electrical	115/60/1, 208-240/60/1/3, 220-240/50/1 and 220/380/50/3
Bowl	14" (355.6mm) diameter, polished, die drawn, 304 stainless steel, 1:1.6 Ratio driven at 24 RPM with "O" Ring Belt Pulley reduction with 45:1 Worm Gear reduction
Housing and bowl cover	Cast Aluminum. Polished and anodized
Switch	DPST Pull/Push On-Off
Cord and plug	3- wire, 16 gauge, 5 ft (1524 mm) long SJT cord with 3 prong mold plug
Net weight	99 lbs. (44.91 kg)
Cube	7.0 Ft.3 (.20 m3)
Dimensions (LxWxH) in	18" x 28" x 16" (457.2mm x 406.4mm x 711.2mm)
Safety features	1. Bowl cover interlock prevents running when cover is in improper position 2. Bowl sensing switch prevents operating without bowl

Detail & Dimensions

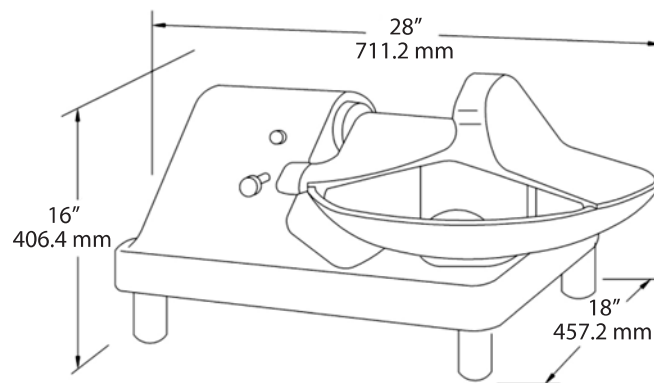

As continued product improvement is a policy of Powerline, specifications are subject to change without notice.



POWERLINE EQUIPMENT COMPANY

Pulaski Street, Norwalk, CT 06851 USA. Tel: 203-847 2357 Fax: 203-847 6480

www.powerlineequip.com